

B|W Controls

Solid State Relays

DESIGN FEATURES

Series 5200 Solid-State Level Control Relays were developed to provide optimum stability and reliability on controlling a wide variety of high and low resistance liquids and moist bulk materials — all well as for general purpose use in applications requiring low voltage control.

Supplied as compact packaged units, they combine performance-proved solid-state printed circuitry with an electromechanical load relay that features isolated double pole/double throw load contacts for energizing pump motors, valves and other operating equipment.

Equipped with silicon controlled rectifiers to assure years of service without change in operating characteristics. They will operate with less than 10% difference between pull-in and drop-out resistance and they can be mounted in any position. Units are field selectable for either direct or inverse operation.

Series 5200 solid state relays are available in two sensitivity ranges—low or high.

UL Recognized and CSA Listed.

SPECIFICATIONS

Dual Voltage: Either 115 or 240 VAC, +10% -20% — 50/60 Hz.

Contacts: Silver cadmium oxide.

Contact Ratings: 10 amperes at 120 or 240 volts ac.—or 28 volts dc.; 1/4 hp at 120 volts ac. and 1/3 hp at 240 volts ac.

Arrangement: Double pole, double throw load contacts plus single pole, double throw holding circuit contacts.

Power Required: 9 voltampere, 6 watt.

Operating Temperature: -40°F to + 180°F

SENSING CIRCUIT:

Low Sensitivity: 8 volt ac and less than 30 ma shortcircuit

High Sensitivity: 9.6 volt dc and less than 1 ma short circuit.

SENSITIVITY: See page 14.

LOW SENSITIVITY RELAY

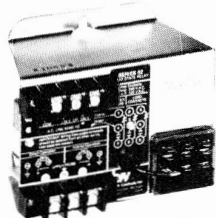

Low Sensitivity Relay
With R1 Fixed Sensitivity
Resistor
Cat No. 5200-LF1-OC

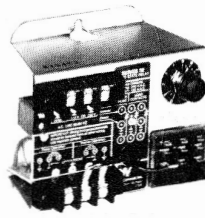

Low Sensitivity Relay
With Variable Sensitivity
Resistor Potentiometer
Cat No. 5200-LV1-OC

The **LOW SENSITIVITY RELAY** is designed for the control or detection of electrically conductive liquids with low to medium specific resistance.

Typical liquids are ordinary potable and waste water, most acids, plating solutions, fruit juices, soups, beer, milk and soft drinks.

With a low voltage A-C electrode potential the **LOW SENSITIVITY RELAY** operates with no shock or sparking hazard, and no product contamination due to electrolysis. It is ideal for food, drug, dairy and chemical processing applications.

HIGH SENSITIVITY RELAY

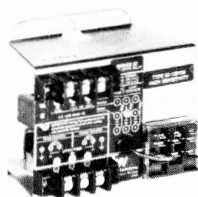

High Sensitivity Relay
With R1 Fixed Sensitivity
Resistor
Cat. No. 5200-HF2-OC

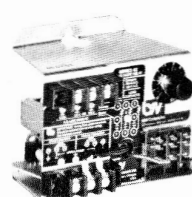

High Sensitivity Relay
With Variable Sensitivity
Resistor Potentiometer
Cat. No. 5200-HV3-OC

The **HIGH SENSITIVITY RELAY** is recommended for the control or detection of electrically conductive liquids with medium to high specific resistance. Typical liquids are distilled and deionized water steam condensate, alcohol, glycols and anhydrous ammonia. It is also suitable for detecting or controlling ore, foundry sand and other bulk materials with low moisture content.

The **HIGH SENSITIVITY RELAY** has a low voltage D-C electrode potential and no shock hazard exists in the electrode circuit. Also, the D-C sensing potential makes this relay an excellent choice for use in applications where the relay must be located many thousands of feet away from the electrodes.

SENSITIVITY SELECTION

BIW level control systems use the liquid as an electrical conductor to complete the Series 5200 relay sensing circuit, and it is necessary that the relay have an operating sensitivity greater than the resistance of the liquid to be controlled. The sensitivity of both models of the Series 5200 relay is determined

by the value of the replaceable R1 resistor used. Since the resistance of liquids vary over a very large range, a wide selection of fixed and variable sensitivities are available as detailed on the chart below.

When operating from contacts of pilot switches, any of the resistors can be used but the smallest R1 resistor value is recommended.

FIXED SENSITIVITY

Both the high and the low sensitivity relays are shipped from the factory with a complete set of fixed resistors. The proper R1 resistor must be selected during installation as shown in the diagrams on page 6. Fixed sensitivity resistors are recommended when operating from pilot switch contacts or when the liquid being controlled is always the same.

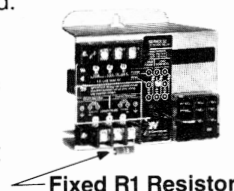

Fixed R1 Resistor

VARIABLE SENSITIVITY

Both high and low sensitivity relays are available with variable resistance potentiometers. A kit can be supplied for field installation. The low sensitivity model has two variable sensitivity ranges and the high sensitivity model has three sensitivity ranges as shown in the table below. Variable sensitivity models are recommended for applications where the relay is to be used on a variety of liquids. They also should be used for interface detection or on applications where foam is present and it is necessary to operate on the liquid phase only.

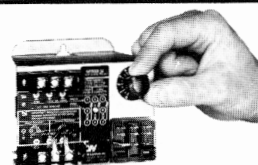

Adjustable R1 Potentiometer

	R1 SENSITIVITY RESISTOR		SENSING CIRCUIT LIMITATIONS		MAXIMUM OPERATING SENSITIVITY	
	Nominal Resistance	Part Number	Maximum Capacitance Electrode Wire to Ground	Maximum Lead Wire Lengths	Direct Operation	Inverse Operation
LOW SENSITIVITY RELAY Maximum Sensitivity Direct Operation: 16,000 Ohms Inverse Operation: 26,000 Ohms Electrode Potential 8 volts A.C. Electrode Current Less than 30 Milliamperes	270 Ohms	04154900	3.7 Microfarads	15,000 feet	200 Ohms	330 Ohms
	470 Ohms	04155000	1.7 Microfarads	15,000 feet	340 Ohms	570 Ohms
	1,000 Ohms	04138300	.80 Microfarads	15,000 feet	730 Ohms	1,200 Ohms
	1,800 Ohms	04155100	.44 Microfarads	11,000 feet	1,300 Ohms	2,200 Ohms
	3,900 Ohms	04155200	.20 Microfarads	5,000 feet	2,800 Ohms	4,800 Ohms
	10,000 Ohms	04149400	.08 Microfarads	2,000 feet	7,300 Ohms	12,000 Ohms
	22,000 Ohms	04138400	.036 Microfarads	900 feet	16,000 Ohms	26,000 Ohms
	Variable	52110205	.80 Microfarads	15,000 feet	100-700 Ohms	200-1200 Ohms
	Variable	52110206	.036 Microfarads	900 feet	.6K-15K Ohms	1K-24K Ohms
	HIGH SENSITIVITY RELAY Maximum Sensitivity Direct Operation: 11.6 Megohms Inverse Operation: 12.0 Megohms Electrode Potential 9.6 volts D.C. Electrode Current Less than 1 Milliampere	10,000 Ohms	04149400	120 Microfarads	50,000 feet	9,600 Ohms
22,000 Ohms		04138400	55 Microfarads	50,000 feet	21,000 Ohms	21,000 Ohms
68,000 Ohms		04138500	18 Microfarads	50,000 feet	66,000 Ohms	66,000 Ohms
.33 Megohms		04138600	4.0 Microfarads	50,000 feet	.31 Megohms	.32 Megohms
.82 Megohms		04138800	1.5 Microfarads	35,000 feet	.80 Megohms	.81 Megohms
2.2 Megohms		04138900	0.5 Microfarads	12,000 feet	2.1 Megohms	2.2 Megohms
5.6 Megohms		04139000	0.2 Microfarads	4,000 feet	5.4 Megohms	5.6 Megohms
12.0 Megohms		04139100	0.1 Microfarads	2,000 feet	11.6 Megohms	12.0 Megohms
Variable		52120205	12 Microfarads	50,000 feet	2K-100K Ohm	2K-100K Ohms
Variable		52120206	1.2 Microfarads	28,000 feet	7K-1.0 Megohms	7K-1.0 Megohms
Variable	52120207	0.2 Microfarads	4,000 feet	47K-5.0 Megohms	47K-5.0 Megohms	

Distances shown in the tables above are based upon the use of two 18-gauge lead wire in 1/2" diameter conduit.

DIRECT AND INVERSE OPERATION

Positive fail-safe control can be obtained simply by connecting the proper R1 resistor to the terminal block for direct or inverse operation as shown in the diagrams at right.

In *direct operation*, the load relay is energized when the liquid contacts the *upper* electrode, or Unifloat® reed switch, and electrode current is flowing. In *inverse operation*, the load relay is energized when the liquid falls below the *lower* electrode, or Unifloat® reed switch, and current ceases to flow.

GROUND CONNECTIONS

In all installations, a good external ground connection and a dependable return circuit to the liquid are required. In most instances, grounding to a metal pipe leading to the tank is suitable, but electrical conduit should not be used for this purpose.

If a good ground connection to the liquid is not available, an additional ground electrode is required. When used, the ground electrode should extend slightly below the longest operating electrode. In addition, it is also desirable to ground the relay chassis directly to ground terminal or through a relay mounting screw.

ELECTRODE LEAD WIRES

Shielded cable is not required, and ordinary insulated wire can be used for electrode leads. Lead wires should be isolated from, not run in the same conduit with, power and load carrying circuits to avoid direct coupling with these circuits. While capacitance of the lead wire to ground has some slight affect on sensitivity, this factor need only be considered when relay is located more than 900 feet away from electrodes.

DIRECT OPERATION FROM B|W ELECTRODES

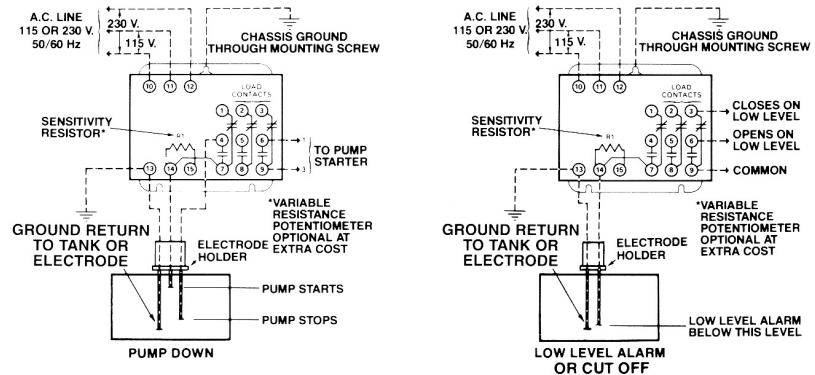

INVERSE OPERATION FROM B|W ELECTRODES

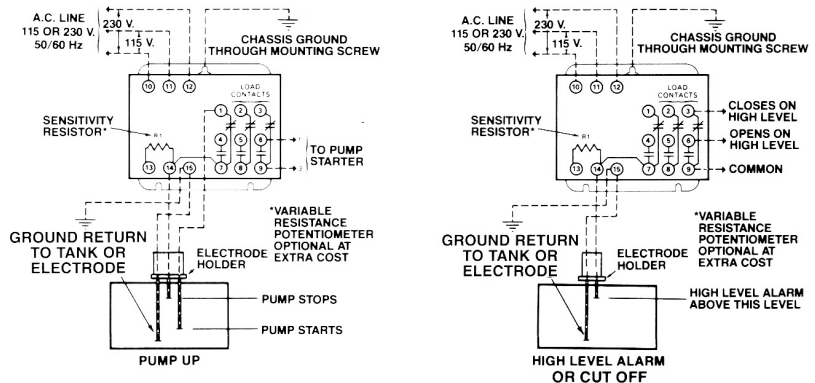

DIRECT OPERATION FROM B|W UNIFLOAT®

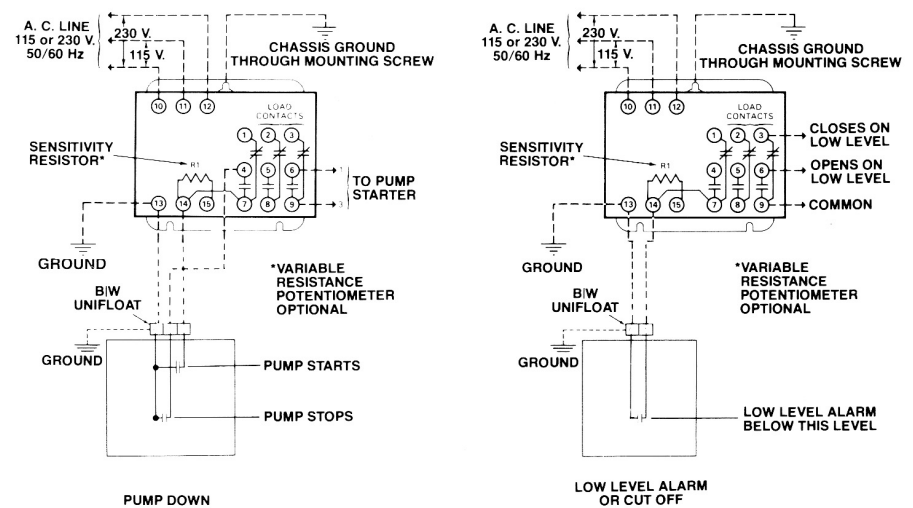



Series 5200 Solid State Relay with replaceable fixed sensitivity resistor R1

PART NO. CROSS REFERENCE

	OLD PART NO.	NEW CAT. NO.
Low Sensitivity	52-110100	5200-LF1-*
	52-110201	5200-LV1-*
	52-110202	5200-LV2-*
High Sensitivity	52-120100	5200-HF2-*
	52-120201	5200-HV3-*
	52-120202	5200-HV4-*
	52-120203	5200-HV5-*

*See Cat. Numbering System for Completion of Catalog Number

5200

Catalog Section

LOW SENSITIVITY CONTROL RELAYS



HIGH SENSITIVITY CONTROL RELAYS

Series 5200 Relay Chassis Dimensions

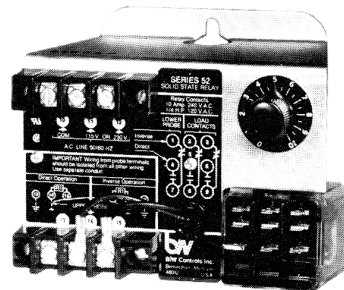
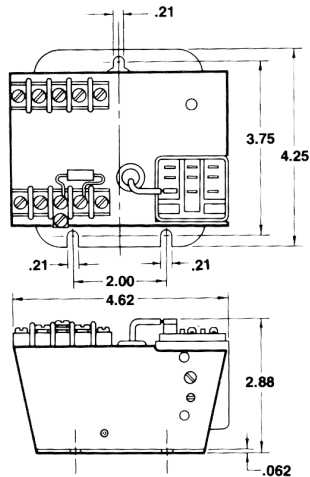

Series 5200 Solid State Relay with variable sensitivity Potentiometer.

SERIES 5200 CATALOG NUMBERING SYSTEM

— LF1 —		N1		
	R1 Sensitivity Resistance	Application Recommendations	TYPE OF ENCLOSURE	
LF1 Fixed	270 ohms	All metallic circuits, BIW Unifloat.	OC Open Chassis	
	470 ohms	Strong electrolytes: Plating solutions.		
	1,000 ohms	Weak electrolytes: Ammonium hydroxide, borax, acetic acid		
	1,800 ohms	Most food processing applications: Beer, wine, fruit juices, milk buttermilk.		
	3,900 ohms	Highly corrosive acid or caustic solutions where electrode current must be minimized to extend electrode life: Hydrochloric acid, sulfuric acid, etc.		
	10,000 ohms	Ordinary water with medium to high mineral content, sewage, water soluble oil and starch solutions.		
	22,000 ohms	Most water with low mineral content. (Soft water—not distilled or deionized water. Use High Sensitivity Relay Control)		
LV1 Variable	Variable 100-700 ohms	Same as above for 270 or 470 or 1000 ohms	N1 Nema 1, General Purpose	
LV2 Variable	Variable .6K-15K ohms	Same as above for 1,800 thru 22,000 ohms		
HF2 Fixed	10,000 ohms	Ordinary water with medium to high mineral content, sewage, water soluble oil and starch solutions, long distance applications		N4 Nema 4, Water Tight
	22,000 ohms	Water with low mineral content (soft water — not distilled or demineralized), sugar syrup solutions, long distance applications.		
	68,000 ohms	Steam condensate, corn syrup, strong alcohol solutions up to 50%		
	330,000 ohms	Alcohol solutions up to 70%		
	820,000 ohms	Deionized or distilled water, 95% glycerine, 90% hydrogen peroxide, 95% ethyl alcohol, granular solids with high moisture content		
	2.2 megohms	Glacial acetic acid, acetone, granular solids with some moisture content		
	5.6 megohms	M.E.K. (Methyl ethyl ketone)		
HV3 Variable	Variable 2K-100K ohms	Same as above for 10,000 thru 68,000 ohms	N4X Nema 4X Fiberglass Water Tight, Dust Tight & Corrosion Resistant	
HV4 Variable	Variable 7K-1.0 megohms	Same as above for 330,000 and 820,000 ohms		
HV5 Variable	Variable 47K-5.0 megohms	Same as above for 2.2 and 5.6 megohms		
			N7 Nema 7, Explosion Proof Class I, Group D, Class II, Group E, F & G	
			N12 Nema 12, Oil Tight	

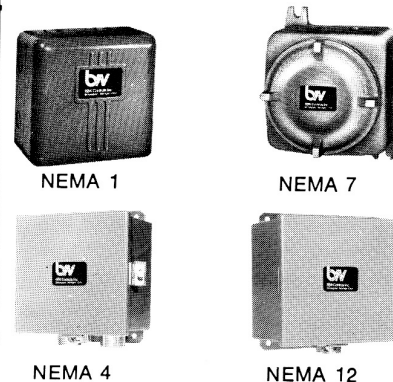

See page 12 for enclosure dimensions.

Note: D1 water, glycols, alcohols and granular solids may require the 2.2, 5.6 or 12.0 megohms R1 resistor depending upon their purity or moisture content.

5200-LF1 and 5200-HF2 Solid State Relays are furnished as standard with a complete set of R1 sensitivity resistors as listed.

Selection of proper resistor should be based on the specific resistance of the material to be controlled. It is important that the R1 resistor selected be rated higher than the resistance of the liquid or other sensing circuit.

LONG DISTANCE AND LOW VOLTAGE REMOTE CONTROL SYSTEM USING THE SERIES 5200 SOLID STATE RELAY

The Series 5200 Solid State Relay is ideal for long distance and low voltage remote control systems. The Series 5200 Low Sensitivity Relay is used for applications requiring AC sensing circuits. The Series 5200 High Sensitivity Relay is used for applications requiring DC sensing circuits.

In general the maximum distance for an AC sensing circuit is limited by the **capacitance** of the wires connecting the relay to the pilot device. If a DC sensing circuit is used, distance is limited by the **resistance** of the control circuit. (See tables below.) In most cases the size of wire is based on the physical strength required to meet given installation conditions. #14 to #18 gauge wire is generally strong enough for private buried or overhead wiring.

The Series 5200 Solid State Relays are capable of performing control functions directly from electrodes or pilot switching devices located **several miles** away.

Telephone circuits and some communication cables use small wires having relatively high resistance. In all cases, however, control circuit wires must have good insulation, and splices or connections must be water-tight and well insulated from ground.

The built-in holding circuit feature shown below allows the Series 5200 Relay to operate over a range of levels and from pushbuttons or other momentary contact switches.

Low Sensitivity 5200-L Relay with 270 ohm R1 resistor: output—8 Volts AC. Current—30 milliamperes. Maximum circuit resistance—200 ohms. Maximum capacitance—3.7 microfarads.

High Sensitivity 5200-H Relay with 10,000 ohm R1 resistor: Output—9.6 Volts DC. Current—1 milliampere. Maximum circuit resistance—9,600 ohms. Maximum capacitance—120 microfarads.

TYPICAL CAPACITANCE AND RESISTANCE VALUES

CONTROL WIRES	CAPACITANCE Mfd/1000 feet
Telephone pair	0.015 mfd
Two #14 in open air	0.02 mfd
Two #14 in 1/2" conduit	0.04 mfd
Two #14 in lead sheath	0.30 mfd
Smaller wires have less capacitance.	

COPPER WIRE SIZE	RESISTANCE Ohms/1000 feet
14 gauge	2.6 ohms
16 gauge	4.1 ohms
18 gauge	6.5 ohms
20 gauge	10.4 ohms
22 gauge	16.5 ohms
24 gauge	26.2 ohms
26 gauge	41.7 ohms

Single function remote control with Series 52 solid state relay operating from pilot switch.

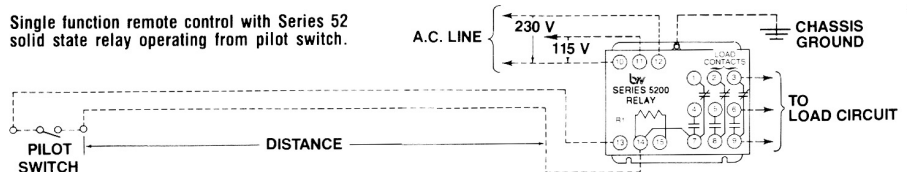

Series 52 solid state relay with built in holding circuit operating from pushbutton contacts.

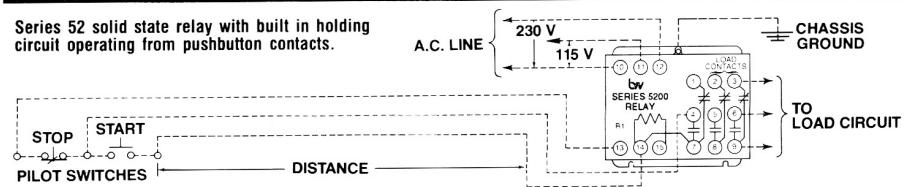

Single Pump/Pump Up Control with no power at tank—Diagram F-1704

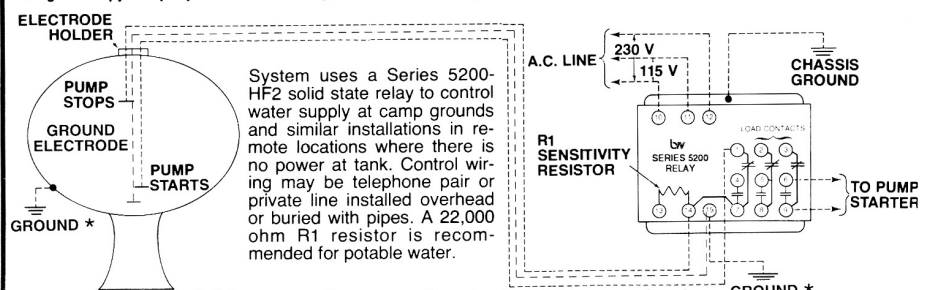

* A good dependable ground connection to liquid is required